

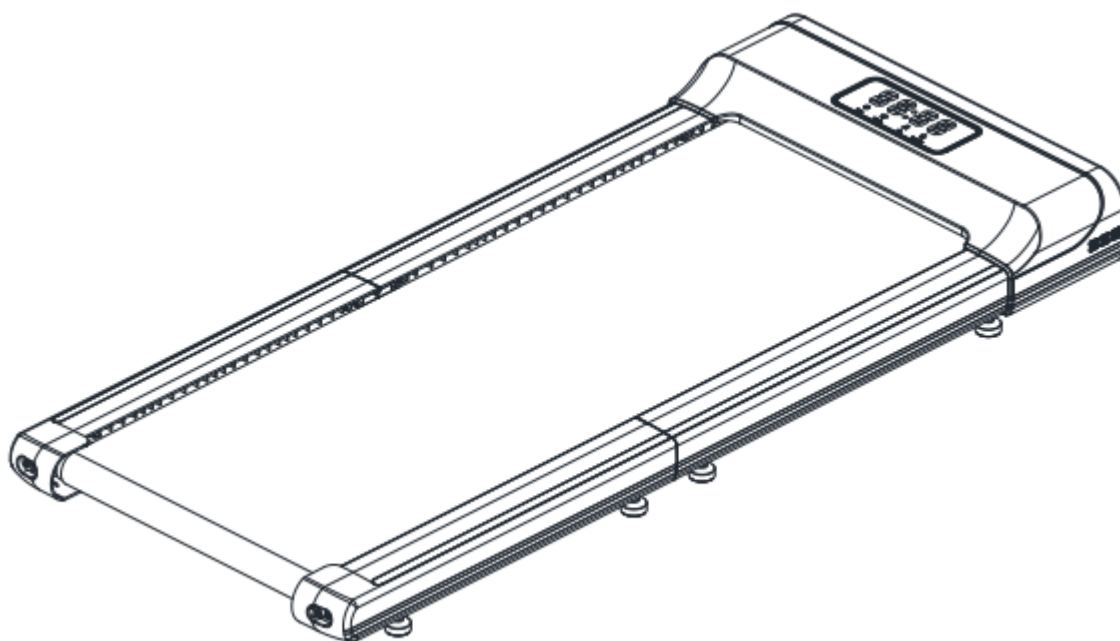

**USER MANUAL – EN**

**IN 26632 Walking treadmill inSPORTline ZenRun Fold 10**



# CONTENTS

SAFETY INSTRUCTIONS..... 3

SPECIFICATIONS..... 3

DIAGRAM..... 4

PARTS LIST ..... 4

PARTS LIST ..... 5

PRODUCT DESCRIPTION ..... 6

ASSEMBLY ..... 6

CONTROL..... 7

ERROR CODES..... 8

GETTING START ..... 9

WARM – UP EXERCISE ..... 9

IMPORTANT NOTICE..... 11

ENVIRONMENT PROTECTION ..... 12

TERMS AND CONDITIONS OF WARRANTY, WARRANTY CLAIMS..... 12

SevenSport s.r.o. reserves the right to make any changes and improvements to its product without prior notice. Visit our website [www.insportline.eu](http://www.insportline.eu) where you will find the latest version of the manual.

## SAFETY INSTRUCTIONS

- Read the manual before assembly and first use and keep it for future reference.
- Never insert any foreign objects into the openings.
- Place the treadmill on a flat and clean surface. Do not place the treadmill on carpets or surfaces that could affect ventilation. Do not place the treadmill near water or outdoors.
- Never stand on the treadmill during start-up, always stand on the sides. After turning on the treadmill and setting the speed, there may be a small delay before the treadmill is set in motion.
- Always wear appropriate sports clothing and footwear. Do not wear loose clothing that could get caught in the treadmill.
- Keep out of reach of children and pets.
- There must be at least 0.6 m of free space around the treadmill.
- Do not exercise 40 minutes after a meal.
- For adults only, teenagers may only use the treadmill under the supervision of an adult.
- When starting for the first time, grasp the handles until you are sure of the speed.
- For indoor use only. Use the treadmill only in a clean and well-ventilated room.
- Do not use extension cords, do not place heavy objects on the power cord, do not place near a heat source, etc.
- Unplug the treadmill when not in use.
- If the power cord is damaged, replace it. Contact a service center or professional for a replacement.
- Keep away from water.
- Do not expose to direct sunlight.
- Do not repair or modify the product.
- If you experience nausea, pain or difficulty breathing, stop operation immediately.
- Keep fingers and limbs away from adjustable and moving parts.
- Unplug after use.
- **Category:** HC for home use.
- **Weight limit:** 120 kg

## SPECIFICATIONS

Speed:	1.0 – 6.0 km/h
Running area:	1060x400 mm
Load capacity:	120 kg
Power:	22 0V, 50Hz
Expanded size:	1283x560x125 mm
Folded size:	843x560x158 mm

# DIAGRAM

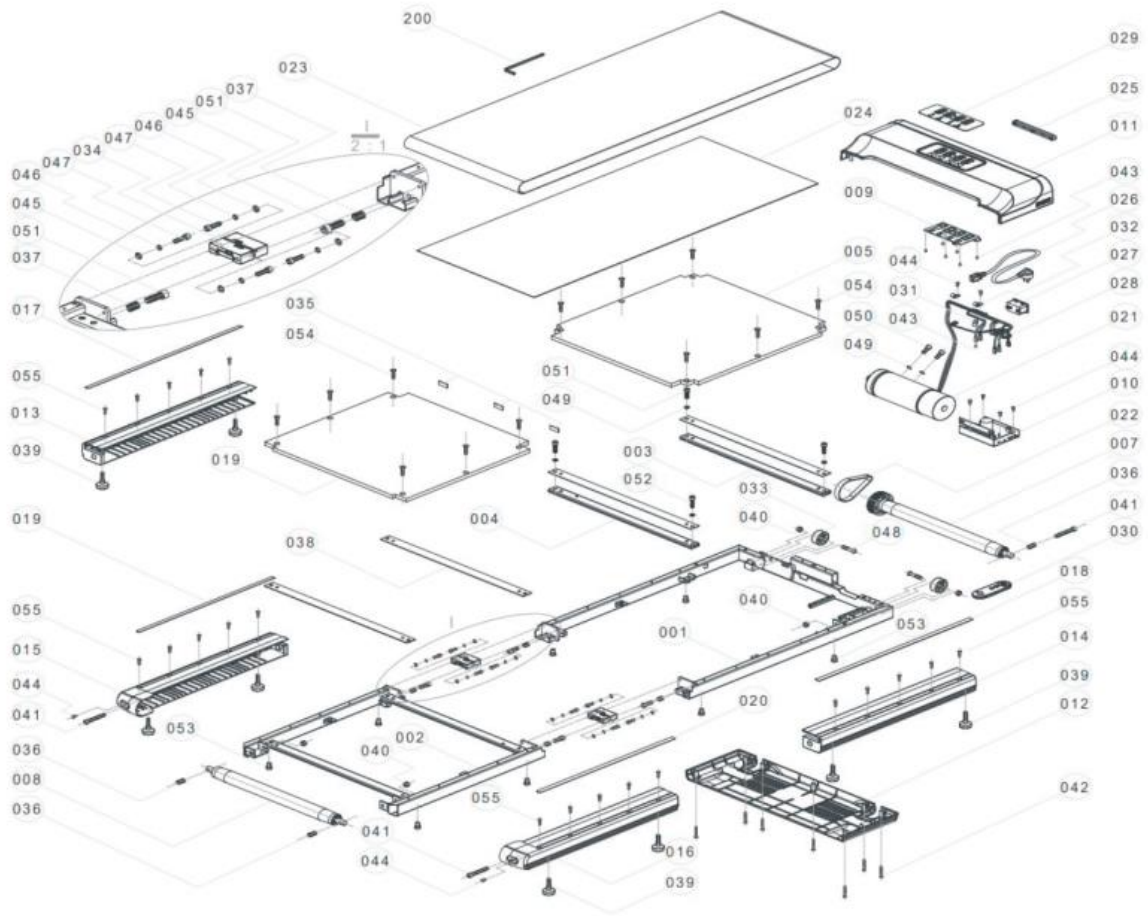

# PARTS LIST

No	Name	Qty.	No.	Name	Qty.
1	Front main frame	1	14.	Right front engine cover	1
2	Rear main frame	1	15.	Left rear cover	1
3	Middle frame	1	16.	Right rear cover	1
4	Rear frame	1	17.	Left front sticker	1
5	Front running board	1	18.	Right front sticker	1
6	Rear running board	1	19.	Left rear sticker	1
7	Front cylinder	1	20.	Right back sticker	1
8	Rear cylinder	1	21.	Motor	1
9	Top engine control	1	22.	Belt	1
10	Lower engine control	1	23.	Running belt	1
11	Engine cover	1	24.	Running belt cushion	1
12	Engine bottom cover	1	25.	Buffer pad	1

13.	Left front side cover	1	26.	Power cable	1
27.	Power switch	1	43.	Phillips screw	7
28.	Cable bundle	1	44.	Phillips screw	8
29.	Display	1	45.	Flat pad	4
30.	Remote controller	1	46.	Flexible mat	4
31.	Cables 01	1	47.	Allen screw	4
32.	Cable harness 02	2	48.	Hexagonal screw	2
33.	Transport wheels	2	49.	Flexible mat	6
34.	Connecting frame	2	50.	Allen screw	2
35.	Running board spacer	3	51.	Allen screw	6
36.	Springs 01	3	52.	Allen screw	2
37.	Springs 02	4	53.	Flat screw	8
38.	Cushioning of the running surface	4	54.	Screw	12
39.	Foot pads	8	55.	Screw	20
40.	Nut	5	200	Cross hex wrench	1
41.	Allen screw	3			
42.	Phillips screw	7			

## PARTS LIST

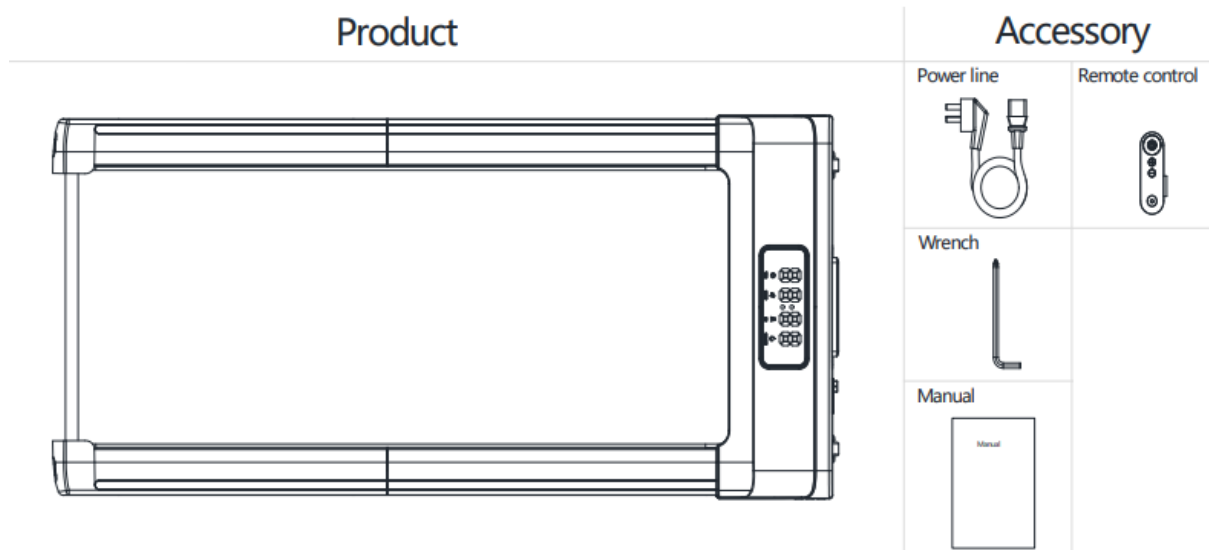

# PRODUCT DESCRIPTION

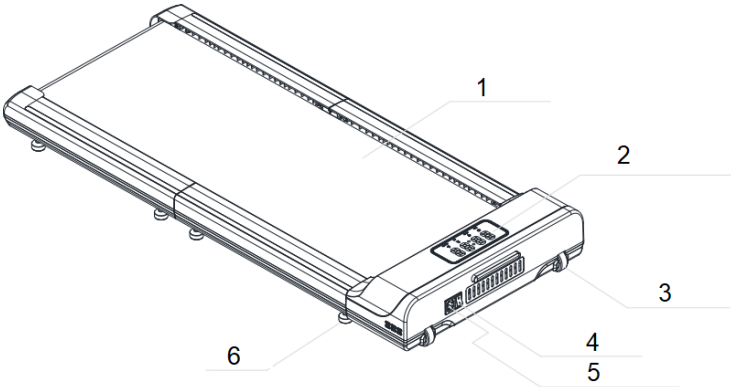

1. Treadmill	4. Power switch
2. Digital display	5. Power supply
3. Transport wheels	6. Leveling feet

# ASSEMBLY

**Step 1**

Take the product and the packaging material out of the box

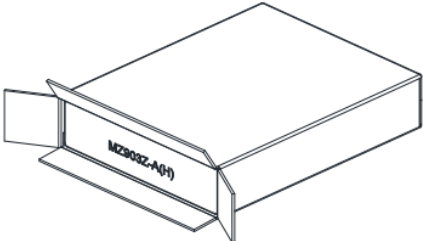

**Step 2**

Remove the packing material.

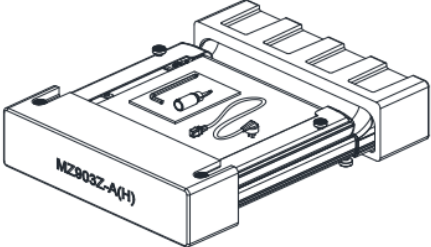

**Step 3**

Unfold the product.

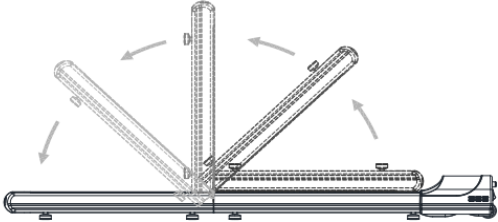

**Step 4**

Plug into the power supply

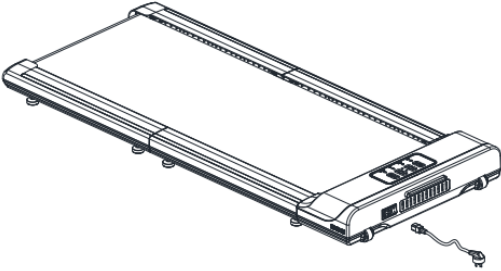

# CONTROL

## DISPLAY

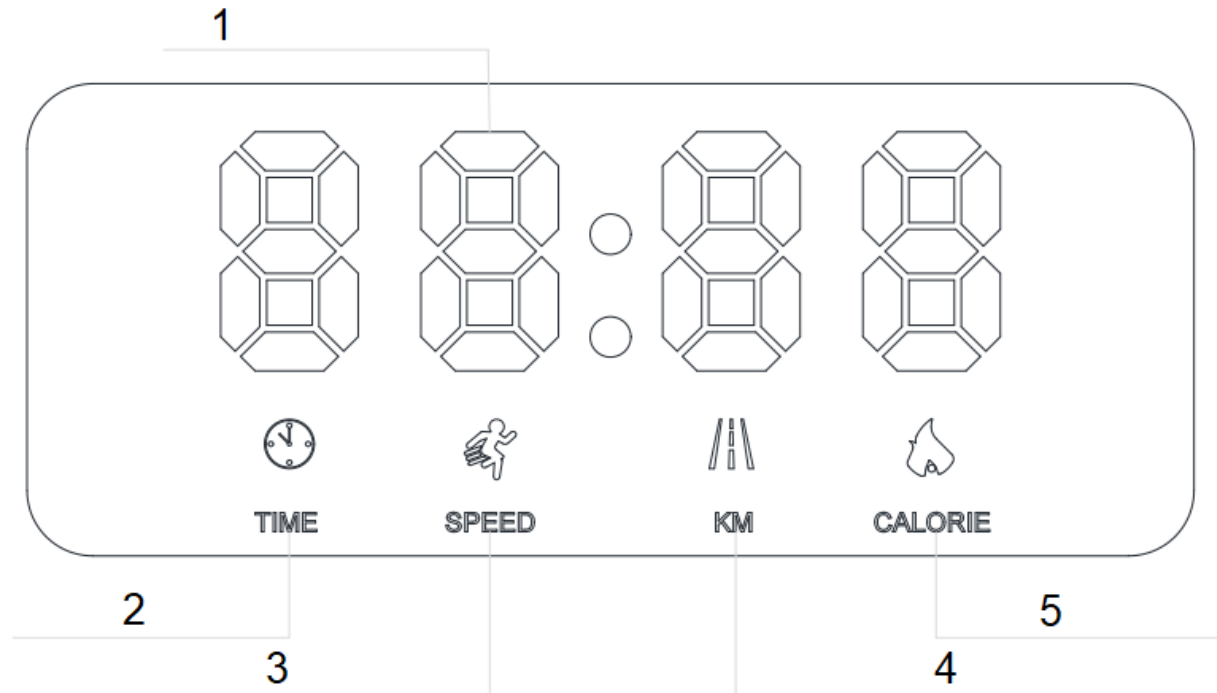

1. Numeric display
2. Training time, range 00:00 – 99:59 min
3. Speed, range: 1 – 6 km/h
4. Distance, range 1.0 – 99.0 km
5. Burned calories, range 20.0 – 990 cal

## CONTROLLER

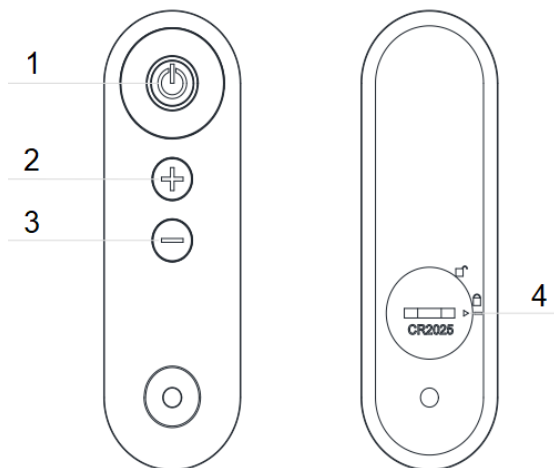

### 1. Power switch

If the belt is stopped, press the button to start the belt, the display will show "1.0"

If the belt is running, pressing the button will reset all data and the belt will begin to slow down until it stops

### 2. Speed +

Press the button to adjust the speed by 0.5 km/h. Holding down will adjust the speed faster

### 3. Speed -

Press the button to adjust the speed by 0.5 km/h. Holding down will adjust the speed faster

### 4. Battery cover

## USE

After plugging in, press the power switch on the controller.

Hold the power button for 3 seconds to start.

## ERROR CODES

E01	Communication Abnormality: Communication abnormality between upper and lower control after power on.	Turning off the bottom control goes into a fault state. Unable to start. The electronic meter displays error codes and beeps three times.  Possible cause: Communication between the electronic control and the electronic meter is blocked. Check the connection between the electronic meter and the lower control communication line to ensure that each core is fully functional inserted. Check the connecting wire between the electronic meter and the controller for damage and replace the connecting wire.
E02	The regulator did not detect the voltage on the motor	Check that the terminal connection of the motor wire to the control is tight
E03	No speed sensor signal: The DC motor control voltage is output from the bottom and the motor speed feedback is not continuous for more than 3 seconds	1. When the machine shuts down and enters the fault state, the electronic meter buzzer will sound 9 times and the error code will be displayed at the same time. The rest of the display does not show any data. After maintaining the fault condition for about 10 seconds, it goes into standby mode and can be restarted.  Possible cause: Speed sensor signal not detected for 3 seconds. Check that the receiver is not connected incorrectly or is not damaged.  2. When the machine shuts down and enters the fault state, the electronic meter buzzer will sound 9 times and the error code will be displayed at the same time. The rest of the display does not show any data. It will return to its original state and can be started normally.  Possible Cause: Check if the motor wires are connected correctly and reconnect them. Check if the regulator is not burned, replace if necessary.
E05	Overvoltage protection: Abnormal supply voltage or motor failure can cause damage to the drive motor circuit	Possible cause: Check that the supply voltage is not less than 50% of the normal voltage. Please test again using the correct voltage specification; Check if the regulator is not burned, replace if necessary. Check that the motor leads are connected correctly
E06	Overcurrent protection: during operation, the DC current of the motor is greater than the rated current for more than 5 seconds	When the machine shuts down and enters the fault state, the electronic meter buzzer will sound 9 times and the error code will be displayed at the same time. The rest of the display does not show any data. After maintaining the fault condition for about 10 seconds, it goes into standby mode and can be restarted.  Possible cause: overvoltage protection or jammed belt motor. Adjust the treadmill and restart. check that some parts do not smell or smoke.
E07	Indicates that the electronic meter has not detected the safety of the signal	Check the position of the magnet



# GETTING START

## PREPARATION

If you are more than 45 years old or have health problems and this is your first time using a treadmill, please consult your doctor before exercising.

Before you use the motorized treadmill, please stand aside and learn how to use it, e.g. how to start, stop and adjust the speed. You can use it after you familiarize yourself with its functions. Then stand on the plastic non-slip side rails and grip the handrail with both hands. Turn the treadmill on and set a low speed (1.6 – 3.2 km/h), stand straight, look forward and try to step onto the running belt a few times with one foot. Then step onto the running belt and start exercising. After you are adapted, you can slowly increase the speed to 3 – 5 km/h and maintain this speed for about 10 minutes. After that, stop the treadmill slowly.

## EXERCISE

Stand aside to learn how to operate the machine (adjusting the speed and inclination). Start exercising after you familiarize yourself with the functions. Walk 1 km in a constant tempo and record the time it takes, which may be about 15 - 25 minutes. Walk 1 km by 4.8 km/h (you need about 12 minutes). After successfully completing this exercise a few times you can adjust to a higher speed and inclination. Have a good 30-minute exercise. When you do walking exercises do not rush. The exercise improves your health.

## FREQUENCY

The optimal exercise frequency is 3 - 5 times per week for 15 – 60 min. It is better to make a schedule first and not exercise randomly. You can control the intensity of the movement through adjusting the speed and inclination. We suggest not to set the inclination when at the start of the exercise. When you want to increase the intensity of the exercise, change in inclination will be the most effective.

## HOW TO EXERCISE

It is best for each exercise to last 15 – 20 min. Warm up for 2 minutes by walking 4.8 km/h, then increase the speed to 5.3 km/h, and then 5.8 km/h. Each section should take about 2 minutes. Then add 0.3 km/h per 2 mins, until your breathing quickens (You should have no difficulty though). Keep exercising at this speed. If you feel it is hard to breathe, lower the speed by 0.3 km/h. Finally, leave 4 minutes to reduce the speed at last. If you find increasing the intensity by increasing speed too hard, you can slowly increase the inclination. Just a small adjustment can increase the intensity greatly.

**BURNING CALORIES** - This way allows you to burn calories. Warm up for 5 minutes at 4 – 4.8 km/h speed, then add 0.3 km/h per every 2 minutes. Keep increasing the speed until you feel it is a challenge to do the exercise continually for 45 minutes. In order to increase intensity, you can try to exercise for 1 hour at this speed. You can exercise while watching TV. Add 0.3 km/h speed every time you see advertisements and return to the former speed by the end of the advertisement so that you increase the intensity only during advertisements. Slow down for at least 4 minutes.

## CLOTHING

All you need is a pair of shoes, which let you stretch your feet fully and at the same time don't stick to foreign matters under your shoe's soles, so that you do not carry dirt onto the running belt and running board. The dirt and other foreign matter could damage them both. You should wear comfortable clothes.

## WARM – UP EXERCISE

It is better to do some warm-up exercises before running. Warmed muscles are easy to stretch, so take the time to do 5 – 10-minute warm-up. Repeat each exercise shown in the pictures below.



### **Touch toes**

Bend your knees slightly and slowly stretch your body downwards.

Relax your back and shoulders. Try to touch the toes. Keep the position for 10 - 15 seconds. Repeat approx. 3 times.



### **Hamstring stretches**

Sitting on a cushion, stretch one leg straight and fold the other inward. Pull it as close to your body as you can. Try your best to touch the toes and keep the stretch for 10 – 15 seconds. Repeat 3 times for each leg.

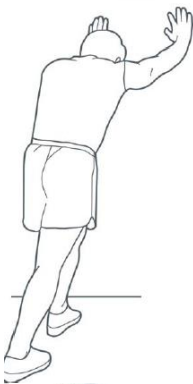

### **Calves and Achilles tendon stretches**

Support yourself with two hands on a wall or a tree with one leg stretched behind you. Keep the leg straight and the heel on the ground. Keep the position for 10 - 15 seconds. Repeat 3 times for each leg.



### **Quadriceps stretches**

Support yourself with your right hand on the wall or a table and stretch your left hand backwards to hold your ankle. Pull it towards your buttocks until you feel tension in your thigh. Keep the position for 10 - 15 seconds. Repeat 3 times for each leg.



### **Inner thigh stretches**

Sit down with your soles touching and knees outward. Pull your feet towards your groin. Keep the position for 10 - 15 seconds. Repeat 3 times.

## IMPORTANT NOTICE

- This treadmill comes with standard safety regulations and is only suitable for home use. Any other use is prohibited and may be dangerous to users. We are not responsible for any injury caused by improper and forbidden use of the machine.
- Consult your doctor before starting training on the treadmill. Your doctor should evaluate whether you are physically fit to use the machine and how much effort you are able to undergo. Incorrect exercise or switching of the body can harm your health.
- Carefully read the following tips and exercises. If you experience pain, nausea, breathing, or other health problems during exercise, immediately stop the exercise. If the pain persists, contact your doctor immediately.
- This treadmill is not suitable as a professional or medical purpose. It can also not be used for healing purposes.
- The heart rate monitor is not a medical device. It provides only approximate information about your average heart rate, and any suggested pulse rate is not medically binding. Accumulated data may not always be accurate regarding uncontrollable human and environmental factors.

## MAINTENANCE

### CLEANING

Regularly clean the belt and treadmill from dust and dirt with a damp cloth and a small amount of non-aggressive detergent.

Always clean the machine from sweat after use.

### LUBRICATION

Check the belt regularly for lubrication. If necessary, lubricate the belt. It is recommended to monitor the lubricant level every month.

Lift the belt on one side and apply the lubricant evenly and as close to the center as possible. Repeat on the other side. Then walk on the belt for 5 min. Use only a silicone lubricant from your supplier.

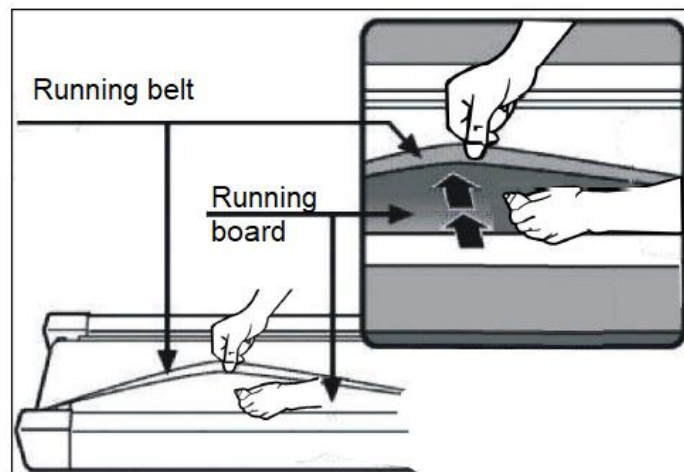

<b>Less than 3 hours a week</b>	Once a year
<b>3 - 5 hours per week</b>	Every 6 months
<b>More than 5 hours a week</b>	Every 3 months

### BELT MIDDLE PLACEMENT AND TIGHTNESS ADJUSTMENT

It is necessary to adjust the belt to the best condition for the better use of the treadmill. Put the treadmill running belt at the centre. Put the motorized treadmill on the level ground. Observe the deviation of the running belt. If the running belt deviates to the right, unplug the power. Turn the right adjusting bolt clockwise by 1/4 turn, plug in the power cord— belt starts to run. Watch the running belt deviations. Repeat the above steps until the running belt is in the middle.

- **Picture A** If the running belt drifts to the left, unplug the treadmill from power. Turn the left adjusting bolt clockwise by 1/4 turn, then plug in the power cord. The belt starts running. Watch if the belt still drifts to the side. Repeat the above steps until the running belt is centred.
- **Picture B.** After the above adjustment or long time use, the running belt could become loose and you will need to adjust it. Pull off the power cord and turn the left and right adjusting bolts clockwise by 1/4 turn. Plug the treadmill back into power– the belt starts running. Then stand on the treadmill to confirm its tightness. Repeat the above steps, until the running belt is tightened correctly (**picture C**).

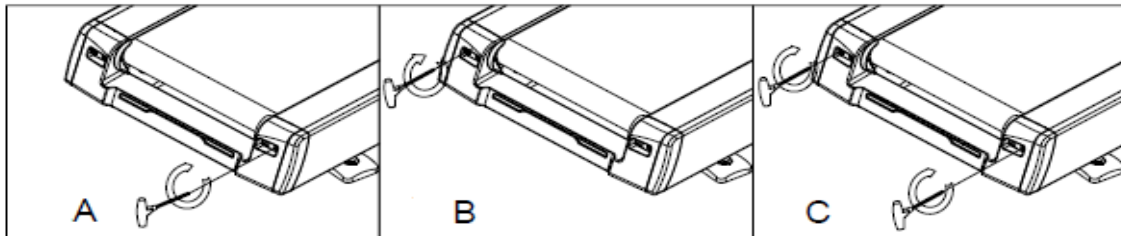

## ENVIRONMENT PROTECTION

After the product lifespan expired or if the possible repairing is uneconomic, dispose it according to the local laws and environmentally friendly in the nearest scrapyard.

By proper disposal you will protect the environment and natural sources. Moreover, you can help protect human health. If you are not sure in correct disposing, ask local authorities to avoid law violation or sanctions.

Don't put the batteries among house waste but hand them in to the recycling place.

## TERMS AND CONDITIONS OF WARRANTY, WARRANTY CLAIMS

### General Conditions of Warranty and Definition of Terms

All Warranty Conditions stated here under determine Warranty Coverage and Warranty Claim Procedure. Conditions of Warranty and Warranty Claims are governed by Act No. 89/2012 Coll. Civil Code, and Act No. 634/1992 Coll., Consumer Protection, as amended, also in cases that are not specified by these Warranty rules.

The seller is SEVEN SPORT s.r.o. with its registered office in Strakonická street 1151/2c, Prague 150 00, Company Registration Number: 26847264, registered in the Trade Register at Regional Court in Prague, Section C, Insert No. 116888.

According to valid legal regulations it depends whether the Buyer is the End Customer or not.

“The Buyer who is the End Customer” or simply the “End Customer” is the legal entity that does not conclude and execute the Contract in order to run or promote his own trade or business activities.

“The Buyer who is not the End Customer” is a Businessman that buys Goods or uses services for the purpose of using the Goods or services for his own business activities. The Buyer conforms to the General Purchase Agreement and business conditions.

These Conditions of Warranty and Warranty Claims are an integral part of every Purchase Agreement made between the Seller and the Buyer. All Warranty Conditions are valid and binding, unless otherwise specified in the Purchase Agreement, in the Amendment to this Contract or in another written agreement.

### Warranty Conditions

#### Warranty Period

The Seller provides the Buyer a 24 months Warranty for Goods Quality, unless otherwise specified in the Certificate of Warranty, Invoice, Bill of Delivery or other documents related to the Goods. The legal warranty period provided to the Consumer is not affected.

By the Warranty for Goods Quality, the Seller guarantees that the delivered Goods shall be, for a certain period of time, suitable for regular or contracted use, and that the Goods shall maintain its regular or contracted features.

**The Warranty does not cover defects resulting from (if applicable):**

- User's fault, i.e. product damage caused by unqualified repair work, improper assembly
- Improper maintenance
- Mechanical damages
- Regular use (e.g. wearing out of rubber and plastic parts, moving mechanisms, joints etc.)
- Unavoidable event, natural disaster
- Adjustments made by unqualified person
- Improper maintenance, improper placement, damages caused by low or high temperature, water, inappropriate pressure, shocks, intentional changes in design or construction etc.

**Warranty Claim Procedure**

The Buyer is obliged to check the Goods delivered by the Seller immediately after taking the responsibility for the Goods and its damages, i.e. immediately after its delivery. The Buyer must check the Goods so that he discovers all the defects that can be discovered by such check.

When making a Warranty Claim the Buyer is obliged, on request of the Seller, to prove the purchase and validity of the claim by the Invoice or Bill of Delivery that includes the product's serial number, or eventually by the documents without the serial number. If the Buyer does not prove the validity of the Warranty Claim by these documents, the Seller has the right to reject the Warranty Claim.

If the Buyer gives notice of a defect that is not covered by the Warranty (e.g. in the case that the Warranty Conditions were not fulfilled or in the case of reporting the defect by mistake etc.), the Seller is eligible to require a compensation for all the costs arising from the repair. The cost shall be calculated according to the valid price list of services and transport costs.

If the Seller finds out (by testing) that the product is not damaged, the Warranty Claim is not accepted. The Seller reserves the right to claim a compensation for costs arising from the false Warranty Claim.

In case the Buyer makes a claim about the Goods that is legally covered by the Warranty provided by the Seller, the Seller shall fix the reported defects by means of repair or by the exchange of the damaged part or product for a new one. Based on the agreement of the Buyer, the Seller has the right to exchange the defected Goods for a fully compatible Goods of the same or better technical characteristics. The Seller is entitled to choose the form of the Warranty Claim Procedures described in this paragraph.

The Seller shall settle the Warranty Claim within 30 days after the delivery of the defective Goods, unless a longer period has been agreed upon. The day when the repaired or exchanged Goods is handed over to the Buyer is considered to be the day of the Warranty Claim settlement. When the Seller is not able to settle the Warranty Claim within the agreed period due to the specific nature of the Goods defect, he and the Buyer shall make an agreement about an alternative solution. In case such agreement is not made, the Seller is obliged to provide the Buyer with a financial compensation in the form of a refund.

**CZ**  
**SEVEN SPORT s.r.o.**

Registered Office: Strakonická 1151/2c, Praha 5, 150 00, ČR  
Headquarters: Dělnická 957, Vítkov, 749 01  
Warranty & Service: Čermenská 486, Vítkov 749 01

CRN: 26847264  
VAT ID: CZ26847264

Phone: +420 556 300 970  
E-mail: [eshop@insportline.cz](mailto:eshop@insportline.cz)  
[reklamace@insportline.cz](mailto:reklamace@insportline.cz)  
[servis@insportline.cz](mailto:servis@insportline.cz)

Web: [www.inSPORTline.cz](http://www.inSPORTline.cz)

**SK**  
**Stores inSPORTline SK, s.r.o.**

Headquarters, warranty & service center: Električná 6471,  
Trenčín 911 01, SK

CRN: 46259317  
VAT ID: SK2023299729

Phone: +421(0) 917 700 098  
E-mail: [objednavky@insportline.sk](mailto:objednavky@insportline.sk)  
[reklamacie@insportline.sk](mailto:reklamacie@insportline.sk)  
[servis@insportline.sk](mailto:servis@insportline.sk)

Web: [www.inSPORTline.sk](http://www.inSPORTline.sk)

**About shipping**

