

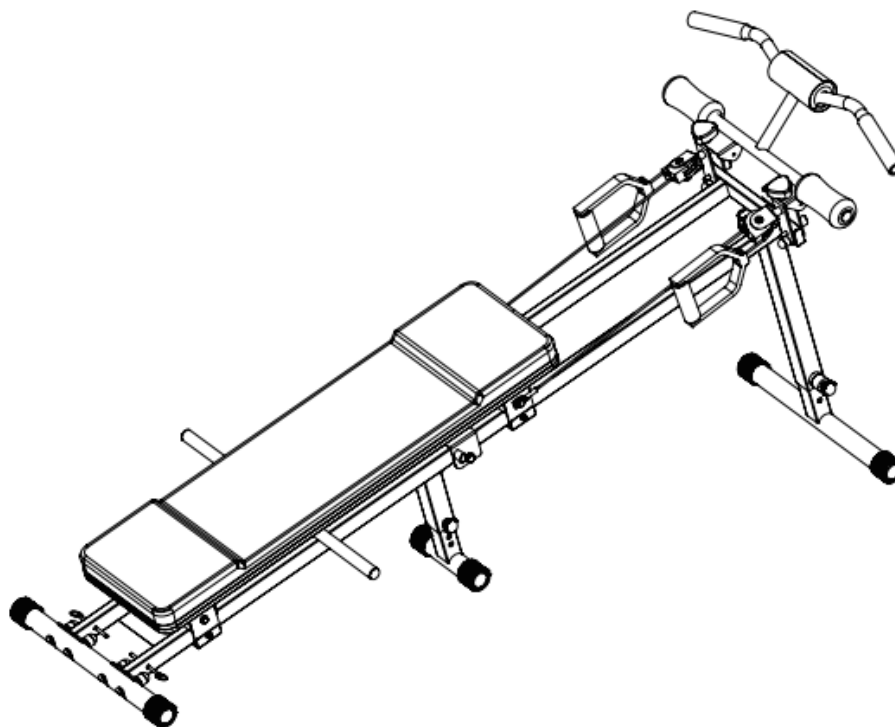

USER MANUAL – EN

IN 25754 Full body trainer inSPORTline Omni-Fit



CONTENTS

- SAFETY INSTRUCTIONS..... 3
- DIAGRAM..... 4
- PARTS LIST 6
- ASSEMBLY 7
- ADJUSTMENT OF BENT HANDLES AND HEIGHT 9
- EXERCISE INSTRUCTIONS 9
 - WARM UP PHASE 10
 - EXERCISE PHASE..... 10
 - COOL DOWN PHASE 11
 - MUSCLE TONING 11
- ENVIRONMENT PROTECTION 11
- TERMS AND CONDITIONS OF WARRANTY, WARRANTY CLAIMS..... 11

SevenSport s.r.o. reserves the right to make any changes and improvements to its product without prior notice. Visit our website www.insportline.eu where you will find the latest version of the manual.

SAFETY INSTRUCTIONS

- Read the manual carefully before use and keep it for future reference.
- Assemble, use and maintain the device only according to the manual. Inform all other users about possible dangers and risks.
- Consult your doctor about your medical condition before starting to exercise to avoid possible injuries. This is especially important if you are taking medications that affect your heart rate, blood pressure, or cholesterol levels.
- Watch your body's signals and pay attention to them. Bad or excessive exercise can be harmful. Stop exercising if you experience any of these symptoms: pain, tightness in the chest, irregular heart rhythm, shortness of breath, numbness, dizziness or nausea. If you feel any of these, stop exercising immediately. Consult your doctor about the next course of action.
- Keep the device out of the reach of children or pets. Only adults can use the device.
- Place the device on a firm, flat and clean surface. For greater safety, keep a distance of min. 0.6 m from other room equipment. Use an underlay to protect your floor covering or carpet.
- Before each exercise, make sure that all screws and nuts are properly tightened.
- Check the device regularly for damage or wear. Damaged or worn parts must be replaced immediately.
- Use the device only in accordance with the manual. Do not carry out any unauthorized modifications or unauthorized maintenance. If you find damaged parts, stop using the device. Do not use the device if it makes unusual noises. Do not even use the device if it has sharp edges.
- Dress appropriately for exercise. Avoid clothes that are too loose and catch easily. Always wear appropriate footwear.
- Keep your hands away from moving parts to avoid injury.
- No adjustable part must protrude so as not to restrict the user's movement.
- Only one person may use the device at a given time.
- The device is for domestic use only. Do not use it outdoors.
- The device is not a medical tool.
- **Maximum user weight:** 136 kg
- **Maximum training weight:** 13.6 kg
- **Category:** H for home use

DIAGRAM

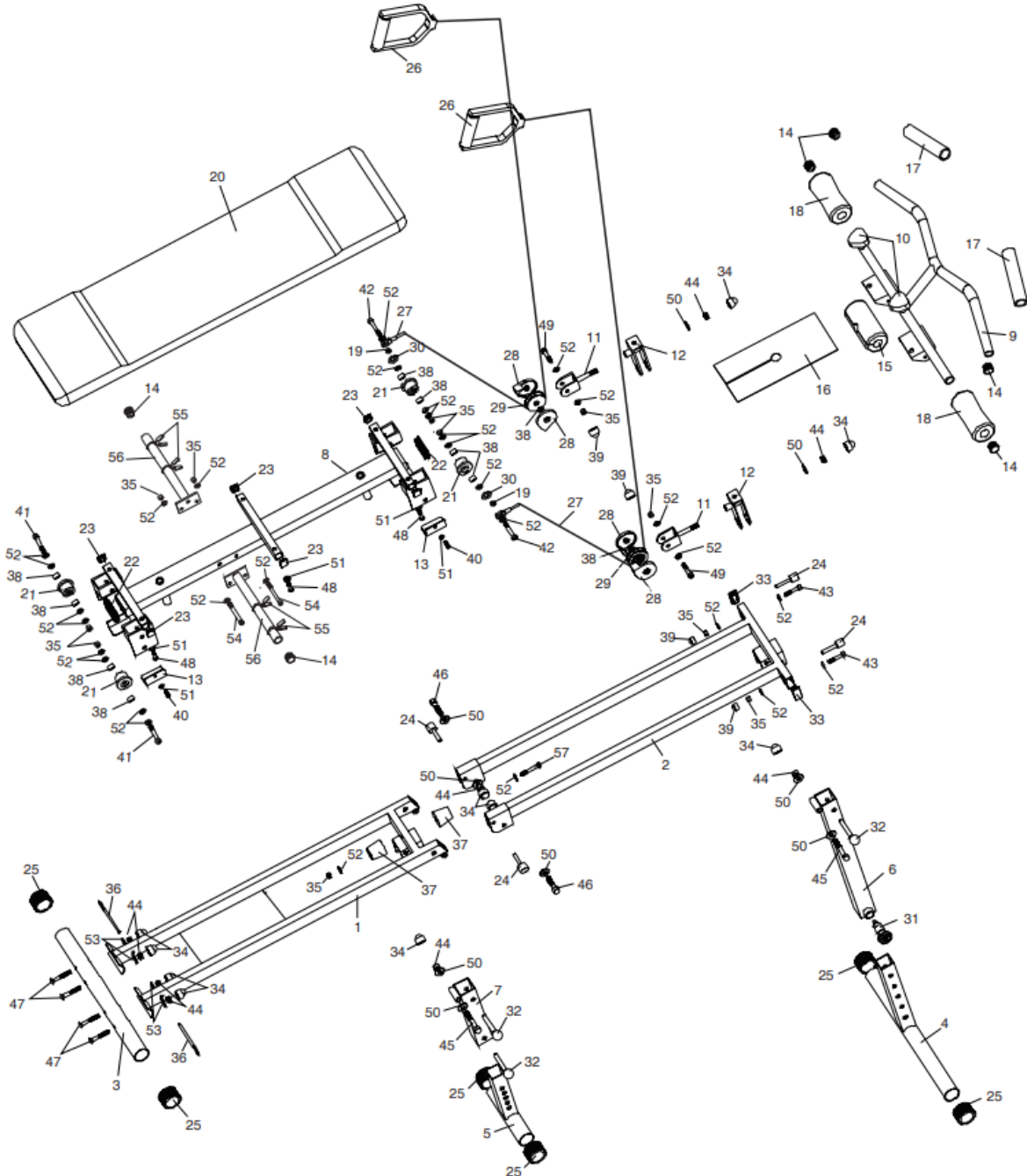

ASSEMBLED DIMENSIONS:

193X69X100cm

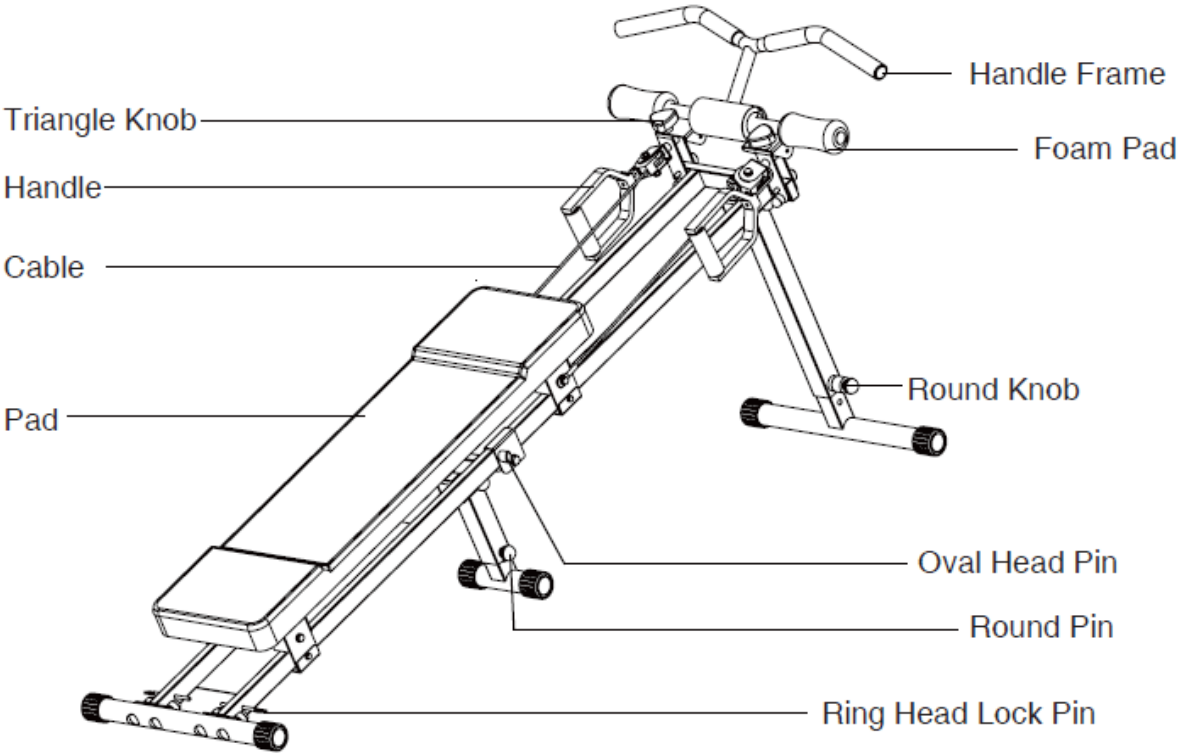

PARTS LIST

No.	Name	Qty.	No.	Name	Qty.
1.	Lower frame	1	30.	Large washer	2
2.	Upper frame	1	31.	Hand knob	1
3.	Back base frame	1	32.	Pin	3
4.	Bottom front base	1	33.	Cover	2
5.	Bottom middle base	1	34.	M10 cap	10
6.	Top front frame	1	35.	M8 nuts	11
7.	Top middle frame	1	36.	Pin	2
8.	Carrier	1	37.	Bumper	1
9.	Bent handles	1	38.	Bearings	10
10.	Triangular hand knob	2	39.	M8 cap	4
11.	Swivel bracket	2	40.	Bolt M6x 10 mm	4
12.	Rotating holder	2	41.	Bolt M8x 50 mm	2
13.	L-bracket	4	42.	Bolt M8x 58 mm	2
14.	Round cap	6	43.	Bolt M8x 40 mm	2
15.	Open foam roller	1	44.	Nut M10	10
16.	Foam roller holder	1	45.	Bolt M10x 65 mm	2
17.	Foam roller	2	46.	Bolt M10x 40 mm	2
18.	Foam roller	2	47.	Carrier bolt M10x 60 mm	4
19.	Spacer ring	2	48.	Bolt M6x 35 mm	6
20.	Seat	1	49.	Bolt M8x 45 mm	2
21.	Wheel	4	50.	Washer M10	10
22.	Frame cover	2	51.	Washer M6	10
23.	Square cap	6	52.	Washer M8	30
24.	Pin	4	53.	M10 curved washer	4
25.	Round cap	6	54.	Bolt M8x 80 mm	2
26.	Handrail	2	55.	Flexible clamp	4
27.	Cable	2	56.	Weight pegs	2
28.	Pulley cover	4	57.	Bolt M8x 65 mm	1
29.	Pulley	2			

ASSEMBLY

Remove the machine from the packaging and lay out all the parts on a flat and clean surface.



Pull out the upper frame (2) and place it on the ground. Be careful not to damage the cable (27)

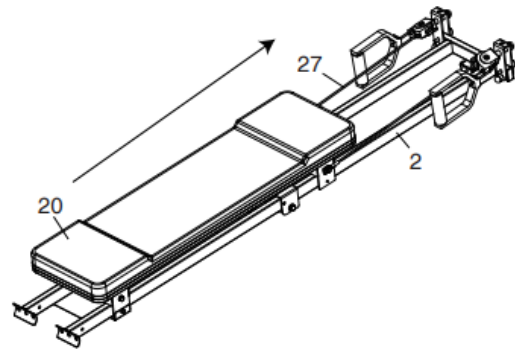

Turn the machine upside down and place it on the floor. Attach the L-bracket (13) to the lower frame (1) with 2x M6 x 10 mm bolts (40) and 2x M6 washers (51). Tighten the nuts. Then insert the pin (24) into the connecting hole between the upper frame (2) and the lower frame (1).

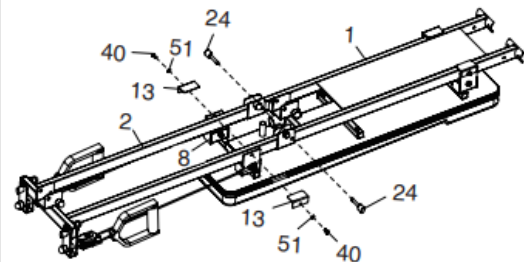

Attach the top front frame (6) to the upper frame (2) with 1x M10 x 65mm bolt (45), 2x M10 washers (50), 1x M10 nut (44), and M10 nut cover (34). Make sure the bolt (45) is inserted into the welded tube on the top front frame (6). Insert the pin (32) into the holes on the top front frame (6) and the bracket on the upper frame (2). Tighten the nut. Next, pull out the pin (31), insert bottom front base (4) into top front frame (6), insert the pin (31) into one of the adjustment holes (A), and screw.

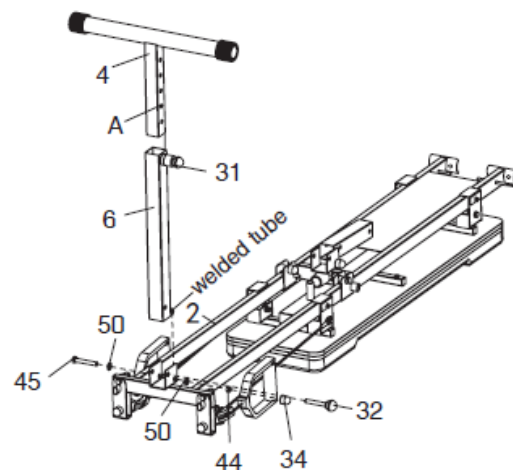

Attach the top middle frame (7) to the bracket on the lower frame (1) with 1x round pin (32). Insert the bottom middle base (5) into top middle frame (7) using the pin (32).

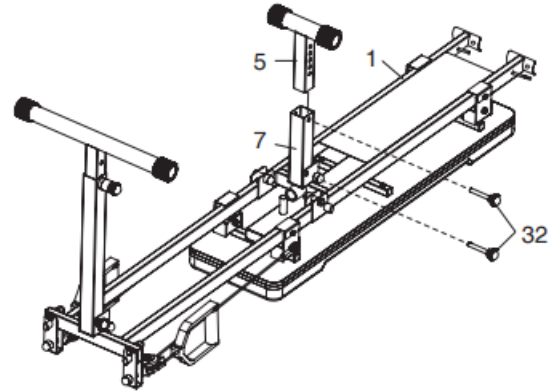

Attach the back base frame (3) to the lower frame (1) with 4x M10 x 60mm carrier bolts (47), 4x curved washers (53), 4x M10 nuts (44), and 4x M10 nut covers (34). Tighten the nuts. Then carefully turn the machine over. Then adjust the bottom middle base (5) and bottom front base (4) so that they are level with the back base frame (3).

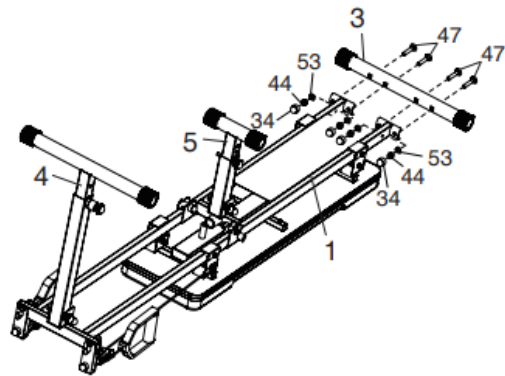

Rotate the swivel bracket (11) up to the position as shown, then secure it to the upper frame (2) with the pins (24).

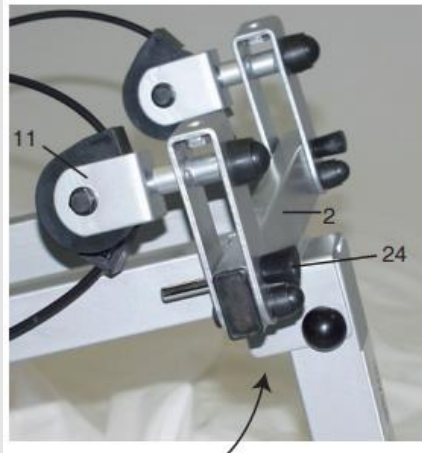

Attach the foam rollers (18) to both sides of the bent handles (9).

Place the open foam roller (15) on the center of the handle (9). Then attach the curved handles (9) to the machine using the 2x triangular hand knobs (10).

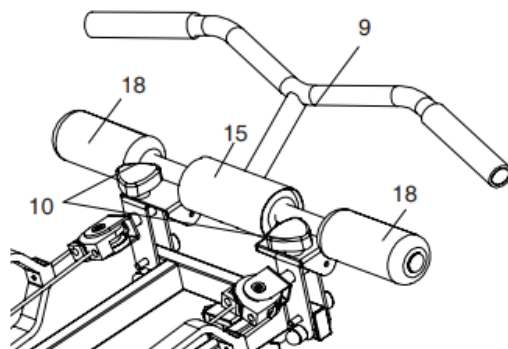

Attach the weight pegs (56) to the seat carrier (8) with 2x M8 x 80mm bolts (54), 4x M8 washers (52), and 2x M8 nuts (35). Then slide the spring clamp (55) against the weight pegs. Tighten the nuts

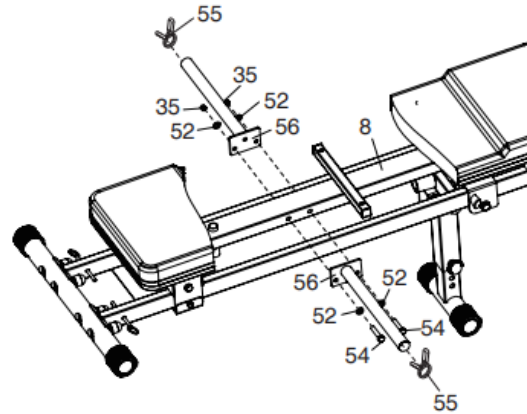

ADJUSTMENT OF BENT HANDLES AND HEIGHT

Attach the bent handles (9) to the lower frame (1) with two pins (36).

Then fully insert the pins (36) into the handles (9) and the lower frame (1).

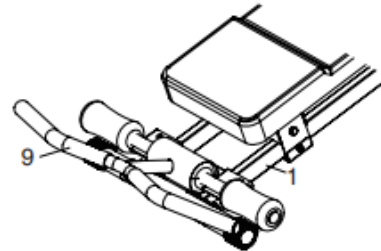
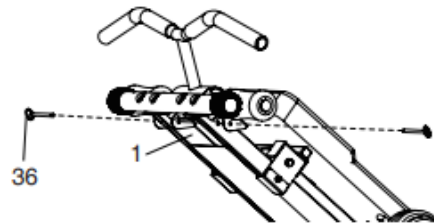

1- Pull out the pin (31) and adjust the bottom front base (4) to the desired position so that the holes are aligned and reattach the pin.

2- Pull out the pin (32) and adjust the bottom middle base (5) to the desired position so that the holes are aligned and reattach the pin.

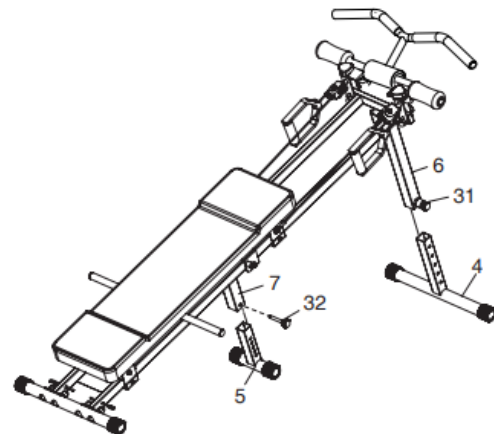



EXERCISE INSTRUCTIONS

Using this device can have a beneficial effect on your physical fitness. It can help in muscle toning and, in a combination with simultaneous calorie-controlled diet, in weight losing.

WARM UP PHASE

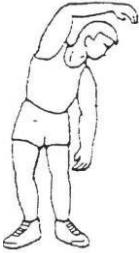
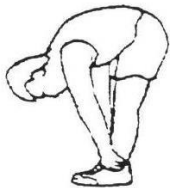
This phase should optimize your blood circulation and warm your muscles to prevent risk of a cramp or muscle injury. It is recommended to take a few stretching exercises as shown below. Hold each stretching for approx. 30 seconds. Don't force or jerk your muscles into a stretch. If you fell pain, stop immediately.

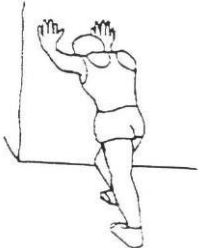
	Side bends
	Forward bends
	Outer thigh
	Inner thigh
	Calves/Achilles tendon

EXERCISE PHASE

At this phase you put the effort in. After regular use, the muscles in your body should get more flexible. Exercise properly and keep steady tempo. The rate of work should be sufficient to raise your heartbeat into the target zone (as on the graph below).

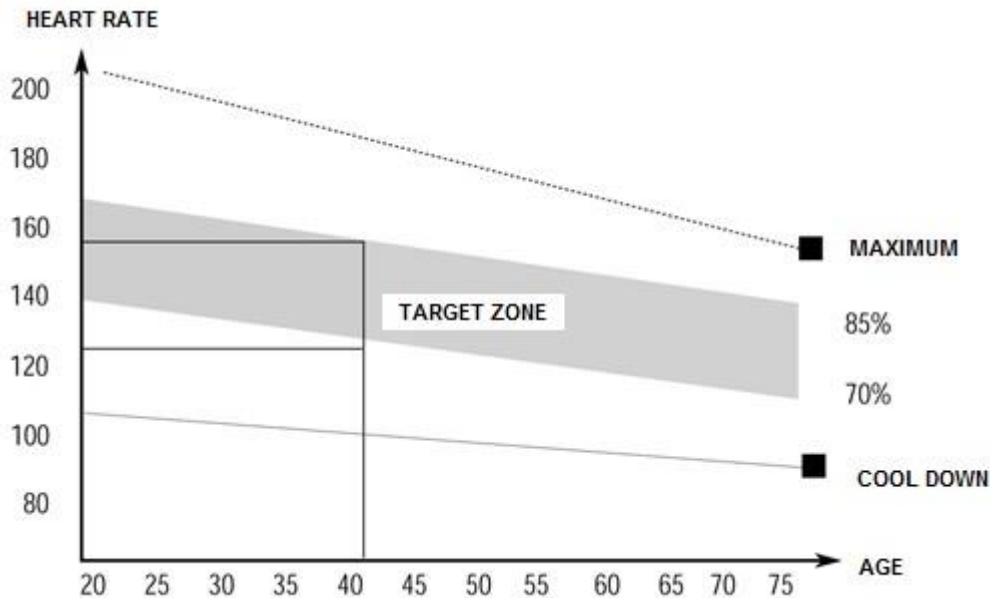

This stage should last for a minimum of 12 minutes though most people start at about 15 – 20 mins.

COOL DOWN PHASE

This phase has to calm your muscles and cardiovascular system. It is repeating of the warm-up exercising, but with reduced tempo. Take it for approx. 5 minutes. You can repeat the stretching exercises, but don't jerk or overstretch your muscles. As you get fitter, you may train longer and harder. It is advisable to train at least three times a week. If possible, space your workouts evenly throughout the week.

MUSCLE TONING

To tone your muscles, you will need to have the resistance set quite high. This will put more strain on your leg muscles and may mean you cannot train for as long as you would like. If you also try to improve your fitness, you need to change your training program. You should train as normal during the warm-up and cool-down phases, but towards the end of the exercise phase you should increase the resistance to make your legs working harder. You have to reduce your speed and keep your heart in the target zone.

ENVIRONMENT PROTECTION

After the product lifespan expired or if the possible repairing is uneconomic, dispose it according to the local laws and environmentally friendly in the nearest scrapyards.

By proper disposal you will protect the environment and natural sources. Moreover, you can help protect human health. If you are not sure in correct disposing, ask local authorities to avoid law violation or sanctions.

Don't put the batteries among house waste but hand them in to the recycling place.

TERMS AND CONDITIONS OF WARRANTY, WARRANTY CLAIMS

General Conditions of Warranty and Definition of Terms

All Warranty Conditions stated here under determine Warranty Coverage and Warranty Claim Procedure. Conditions of Warranty and Warranty Claims are governed by Act No. 89/2012 Coll. Civil Code, and Act No. 634/1992 Coll., Consumer Protection, as amended, also in cases that are not specified by these Warranty rules.

The seller is SEVEN SPORT s.r.o. with its registered office in Strakonická street 1151/2c, Prague 150 00, Company Registration Number: 26847264, registered in the Trade Register at Regional Court in Prague, Section C, Insert No. 116888.

According to valid legal regulations it depends whether the Buyer is the End Customer or not.

“The Buyer who is the End Customer” or simply the “End Customer” is the legal entity that does not conclude and execute the Contract in order to run or promote his own trade or business activities.

“The Buyer who is not the End Customer” is a Businessman that buys Goods or uses services for the purpose of using the Goods or services for his own business activities. The Buyer conforms to the General Purchase Agreement and business conditions.

These Conditions of Warranty and Warranty Claims are an integral part of every Purchase Agreement made between the Seller and the Buyer. All Warranty Conditions are valid and binding, unless otherwise specified in the Purchase Agreement, in the Amendment to this Contract or in another written agreement.

Warranty Conditions

Warranty Period

The Seller provides the Buyer a 24 months Warranty for Goods Quality, unless otherwise specified in the Certificate of Warranty, Invoice, Bill of Delivery or other documents related to the Goods. The legal warranty period provided to the Consumer is not affected.

By the Warranty for Goods Quality, the Seller guarantees that the delivered Goods shall be, for a certain period of time, suitable for regular or contracted use, and that the Goods shall maintain its regular or contracted features.

Batteries

6-month battery warranty – we guarantee that battery's nominal capacity does not fall below 70% of its total capacity within 6 months of the product's sale.

The Warranty does not cover defects resulting from (if applicable):

- User's fault, i.e. product damage caused by unqualified repair work, improper assembly, insufficient insertion of seat post into frame, insufficient tightening of pedals and cranks
- Improper maintenance
- Mechanical damages
- Regular use (e.g. wearing out of rubber and plastic parts, moving mechanisms, joints, wear of brake pads/blocks, chain, tires, cassette/multi wheel etc.)
- Unavoidable event, natural disaster
- Adjustments made by unqualified person
- Improper maintenance, improper placement, damages caused by low or high temperature, water, inappropriate pressure, shocks, intentional changes in design or construction etc.

Warranty Claim Procedure

The Buyer is obliged to check the Goods delivered by the Seller immediately after taking the responsibility for the Goods and its damages, i.e. immediately after its delivery. The Buyer must check the Goods so that he discovers all the defects that can be discovered by such check.

When making a Warranty Claim the Buyer is obliged, on request of the Seller, to prove the purchase and validity of the claim by the Invoice or Bill of Delivery that includes the product's serial number, or eventually by the documents without the serial number. If the Buyer does not prove the validity of the Warranty Claim by these documents, the Seller has the right to reject the Warranty Claim.

If the Buyer gives notice of a defect that is not covered by the Warranty (e.g. in the case that the Warranty Conditions were not fulfilled or in the case of reporting the defect by mistake etc.), the Seller is eligible to require a compensation for all the costs arising from the repair. The cost shall be calculated according to the valid price list of services and transport costs.

If the Seller finds out (by testing) that the product is not damaged, the Warranty Claim is not accepted. The Seller reserves the right to claim a compensation for costs arising from the false Warranty Claim.

In case the Buyer makes a claim about the Goods that is legally covered by the Warranty provided by the Seller, the Seller shall fix the reported defects by means of repair or by the exchange of the damaged part or product for a new one. Based on the agreement of the Buyer, the Seller has the right to exchange the defected Goods for a fully compatible Goods of the same or better technical characteristics. The Seller is entitled to choose the form of the Warranty Claim Procedures described in this paragraph.

The Seller shall settle the Warranty Claim within 30 days after the delivery of the defective Goods, unless a longer period has been agreed upon. The day when the repaired or exchanged Goods is handed over to the Buyer is considered to be the day of the Warranty Claim settlement. When the Seller is not able to settle the Warranty Claim within the agreed period due to the specific nature of the Goods defect, he and the Buyer shall make an agreement about an alternative solution. In case such agreement is not made, the Seller is obliged to provide the Buyer with a financial compensation in the form of a refund.

CZ
SEVEN SPORT s.r.o.

Registered Office: Strakonická 1151/2c, Praha 5, 150 00, ČR
Headquarters: Dělnická 957, Vítkov, 749 01
Warranty & Service: Čermenská 486, Vítkov 749 01

CRN: 26847264
VAT ID: CZ26847264
Phone: +420 556 300 970
E-mail: eshop@insportline.cz
reklamace@insportline.cz
servis@insportline.cz

Web: www.inSPORTline.cz

SK
Stores inSPORTline SK, s.r.o.

Headquarters, warranty & service center: Električná 6471,
Trenčín 911 01, SK

CRN: 46259317
VAT ID: SK2023299729
Phone: +421(0) 917 700 098
E-mail: objednavky@insportline.sk
reklamacie@insportline.sk
servis@insportline.sk

Web: www.inSPORTline.sk

About shipping

